

Agilent

N8480 Series Thermocouple Power Sensors

Technical Overview



Agilent Technologies

Introduction

The new N8480 Series power sensors replace and surpass the legacy 8480 Series power sensors (excluding the D-model power sensors) in terms of its functionality and performance. A few of the key features offered are built-in Electrically Erasable Programmable Read-Only Memory (EEPROM), extended dynamic range, wider frequency range, and most important of all, higher accuracy and repeatability.

Theory of Operation

The new thermocouple integrated circuit (IC) is the major core improvement in the N8480 Series power sensors. The new IC not only inherits excellent linearity from the legacy 8480 power sensors but also extends the sensors' dynamic range to -35 dBm, the lowest power measurement in the thermocouple power measurement solution.

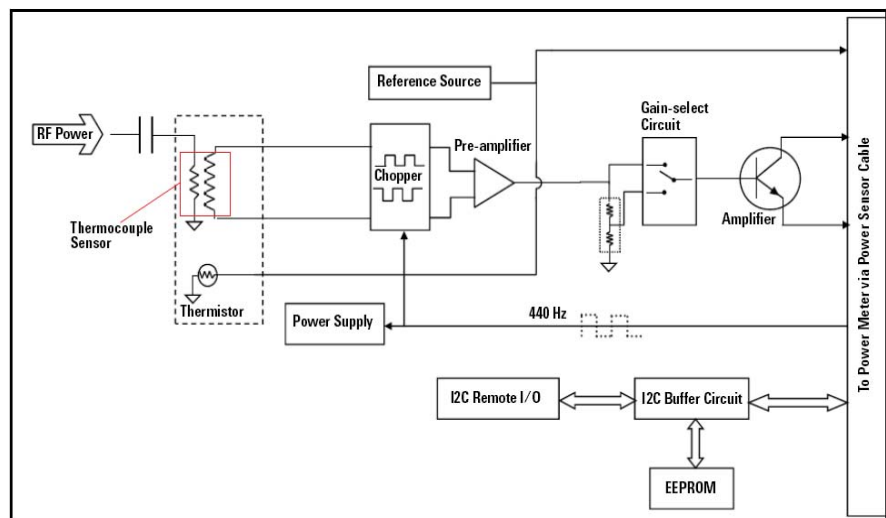

Figure 1. N8480 Series power sensor simplified block diagram

Figure 1 shows a basic power sensor block diagram for the thermocouple power-sensing elements. With reference to the block diagram, the new IC will convert any detected radio frequency (RF) power into a differential DC signal, and transmit the signal to the chopper circuit via a carefully designed differential path and layout. Then, a triggered 440 Hz power meter's chopping signal is used to chop the DC signal into an AC signal. This process helps to decrease the electronic noise that occurs during the signal amplification, apart from the DC signal's drift that enters the amplifier.

The AC signal is amplified twice before it is transmitted to the power meter. The first stage amplifier is a differential instrumentation amplifier. It cancels the noise or thermocouple effect at the front end, thereby reducing the overall electronics noise floor by more than 50% compared to the legacy 8480 Series power sensors. The second stage amplifier is a conventional interface amplifier. It is used for signal amplification, as well as to match enable the power sensors with the Agilent power meters.

The gain selection circuit is a new component added to the N8480 Series power sensors. This component optimizes the amplifier gain setting between the two stages of amplification and improves the power sensor's performance in different dynamic ranges.

The thermistor in Figure 1 is the key element of the N8480 Series power sensors. It functions as a temperature sensing instrument as well as a feed indicator to the power meters during compensation. This computation is done by the connected power meter and it is used to minimize any sensor drift across the operating temperature range.

The EEPROM serves as a register to store the calibration factors that carry the characteristics of a power sensor. The N8480 Series power sensors have been improved by optimizing algorithm structure functions to calculate the calibration factors and achieve better linearity and temperature compensation performance. The I²C buffer circuit and I²C remote I/O circuit function to control buses that transfer the data within the power sensor's EEPROM and power meter.

With all the improvement in the new thermocouple IC, electronic design, and introduction of a new correction algorithm, Agilent is now offering the power sensors with the widest dynamic range in the thermocouple measurement market. The N8480 Series power sensors provide better accuracy and power linearity compared to the legacy 8480 Series power sensors, in addition to the minimum measurement drift over temperature. These power sensors also offer easy start-up setting for RF power measurements.

Why Choose the N8480 Series Power Sensors?

Accurate power measurement

The newly improved N8480 Series power sensors provide:

- Wide dynamic range up to 55 dB
- Minimum power linearity performance of $\pm 0.52\%$
- Best-in-class power measurement accuracy of less than 1% (with reference of 0 dBm at 50 MHz)
- More than 50% improvement in measurement repeatability.

Figure 2 illustrates the N8481A power sensor's accuracy and repeatability improvement compared to the legacy 8481A power sensor.

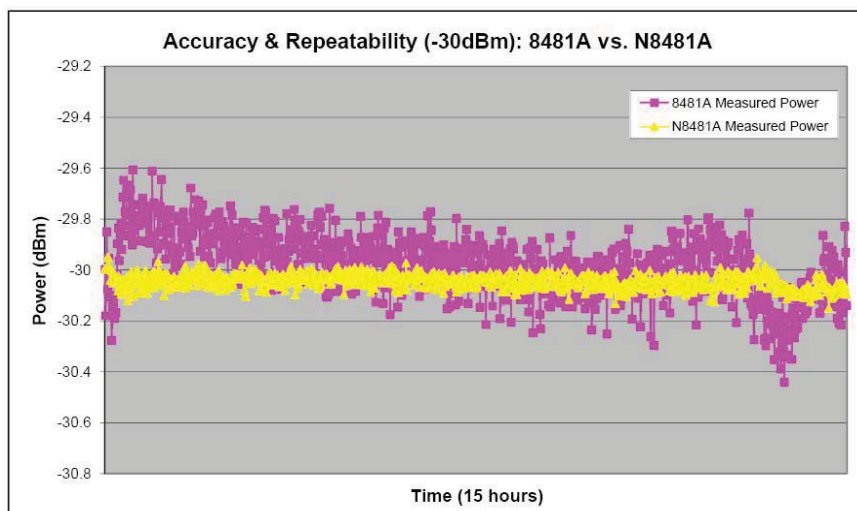

Figure 2. Power measurement comparison between the N8481A and legacy 8481A power sensor

Convenient power measurement setting

The N8480 Series power sensors have a built-in EEPROM, which allows the calibration factors to be loaded automatically to the power meter whenever the power sensors are connected to the power meter.

Low cost with accurate power measurement

The N8480 Series power sensors are affordable and a low-cost solution for accurate power measurement.

Temperature-proof power measurement

The N8480 Series power sensors are designed to be temperature sensitive. With the help of the optimized algorithm computation, the power measurement drift over temperature is minimized.

N8480 Series Power Sensors in Today's Wireless Signal Measurement

Agilent is a leading innovator in the power sensors and power meters markets. One of its outstanding and recognizable products is the legacy 8480 Series power sensor, a thermocouple sensor technology introduced in the early 1970s. These power sensors can respond to the heat generated by the signal under test regardless of the type of signal. Hence, the new N8480 Series power sensors not only can measure the true average power for continuous waveform (CW) and true average signal, but can also measure complex modulated signals such as Music Local Area Network (mLAN), Worldwide Inter-operability for Microwave Access (WiMAX), and even pulse signals — with better accuracy, repeatability, and reliability.



Agilent Email Updates

www.agilent.com/find/emailupdates
Get the latest information on the products and applications you select.



Agilent Direct

www.agilent.com/find/agilentdirect
Quickly choose and use your test equipment solutions with confidence.



www.agilent.com/find/open
Agilent Open simplifies the process of connecting and programming test systems to help engineers design, validate and manufacture electronic products. Agilent offers open connectivity for a broad range of system-ready instruments, open industry software, PC-standard I/O and global support, which are combined to more easily integrate test system development.

Microsoft is a U.S. registered trademark of Microsoft Corporation.

Remove all doubt

Our repair and calibration services will get your equipment back to you, performing like new, when promised. You will get full value out of your Agilent equipment throughout its lifetime. Your equipment will be serviced by Agilent-trained technicians using the latest factory calibration procedures, automated repair diagnostics and genuine parts. You will always have the utmost confidence in your measurements. For information regarding self maintenance of this product, please contact your Agilent office.

Agilent offers a wide range of additional expert test and measurement services for your equipment, including initial start-up assistance, onsite education and training, as well as design, system integration, and project management.

For more information on repair and calibration services, go to:

www.agilent.com/find/removealldoubt

Product specifications and descriptions in this document subject to change without notice.

www.agilent.com
www.agilent.com/find/thermocouplesensor

For more information on Agilent Technologies' products, applications or services, please contact your local Agilent office. The complete list is available at:

www.agilent.com/find/contactus

Americas

Canada	(877) 894-4414
Latin America	305 269 7500
United States	(800) 829-4444

Asia Pacific

Australia	1 800 629 485
China	800 810 0189
Hong Kong	800 938 693
India	1 800 112 929
Japan	0120 (421) 345
Korea	080 769 0800
Malaysia	1 800 888 848
Singapore	1 800 375 8100
Taiwan	0800 047 866
Thailand	1 800 226 008

Europe & Middle East

Austria	01 36027 71571
Belgium	32 (0) 2 404 93 40
Denmark	45 70 13 15 15
Finland	358 (0) 10 855 2100
France	0825 010 700*
	*0.125 €/minute
Germany	07031 464 6333
Ireland	1890 924 204
Israel	972-3-9288-504/544
Italy	39 02 92 60 8484
Netherlands	31 (0) 20 547 2111
Spain	34 (91) 631 3300
Sweden	0200-88 22 55
Switzerland	0800 80 53 53
United Kingdom	44 (0) 118 9276201
Other European Countries:	www.agilent.com/find/contactus

Revised: October 6, 2008

© Agilent Technologies, Inc. 2009
Printed in USA, March 20, 2009
5990-3857EN



Agilent Technologies